

DIN Rail terminal blocks / WPMS series

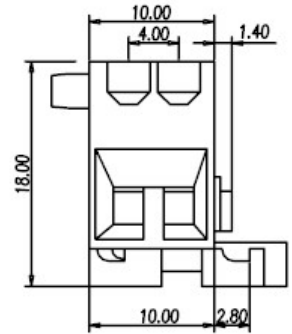

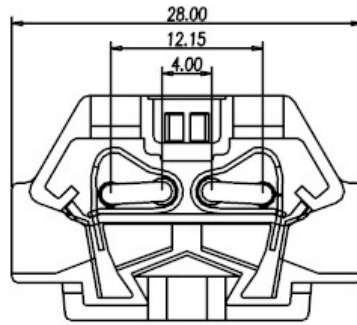

WPPMS2.5



TxHxW 10x28x18

Approval		
Technical Data	UL	IEC
Rated voltage	600V	660V
Rated current	25A	24A
Wire range		
Solid wire (AWG mm ²)	28~12	0.5~2.5
Stranded wire (AWG mm ²)	14~12	0.5~2.5
Rated surge voltage (UL/IEC/Max.)	2.2 / 2.5 / 8 KV	
Torque (Lb-in)		
Screw		
Wire strip length	7~8mm	

Accessories	Cat. No.
End cover	WPMS2.5C
Partition	
Small partition	
Cross jumper - central type	DS-204
Marking label	TM10
Suitable rail	
Tool	SDM4.0
Pole	Cat. No.
1P	WPPMS2.5-01P
With end cover	WPPMS2.5C
02	WPPMS2.5-02P
03	WPPMS2.5-03P
04	WPPMS2.5-04P
06	WPPMS2.5-06P
08	WPPMS2.5-08P
:	:
:	:
Optional color	Cat. No.
	WPPMS2.5A-XXP-OR
	WPPMS2.5A-XXP-YG